

[54] COLD CATHODE VACUUM DISCHARGE TUBE WITH CATHODE DISCHARGE FACE PARALLEL WITH ANODE

[72] Inventor: Gordon E. Boettcher, Albuquerque, N. Mex.

[73] Assignee: The United States of America as represented by the United States Atomic Energy Commission

[22] Filed: Feb. 24, 1967

[21] Appl. No.: 619,137

[52] U.S. Cl. .... 313/178, 313/197, 313/355, 315/330

[51] Int. Cl. .... H01j 19/44, H01j 19/70

[58] Field of Search .....315/330; 313/178, 179, 355, 181, 174, 197

[56] References Cited

UNITED STATES PATENTS

3,087,092 4/1963 Lafferty .....313/197

Primary Examiner—Carl D. Quarforth  
Assistant Examiner—Roger S. Gaither  
Attorney—Roland A. Anderson

[57] ABSTRACT

A cold cathode vacuum discharge tube having an anode separated from a cold cathode by a vacuum discharge gap, a gas generating trigger probe contiguous with said cathode and gettering means, together with various embodiments and circuitry.

7 Claims, 8 Drawing Figures

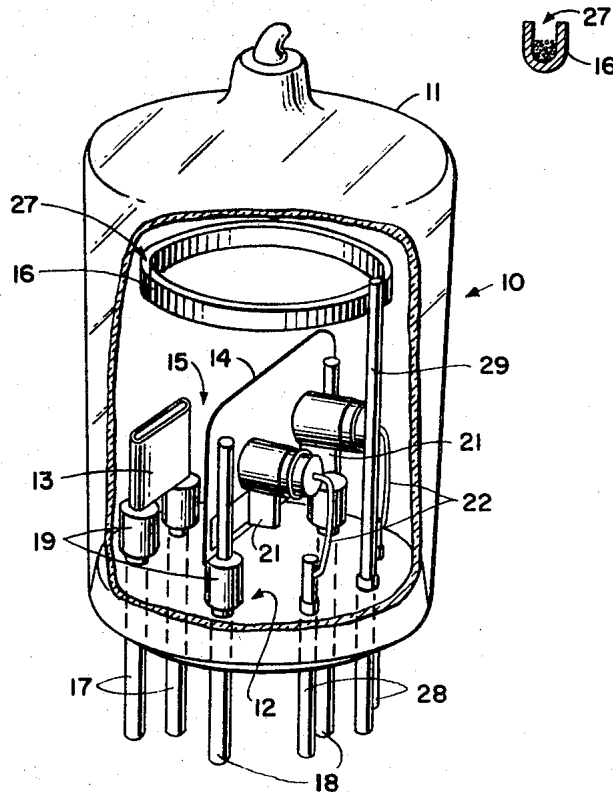

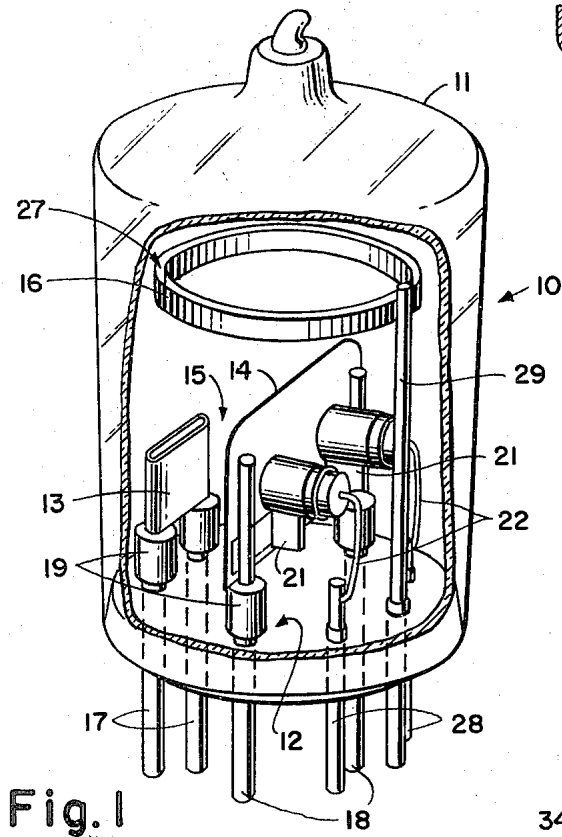

Fig. 1

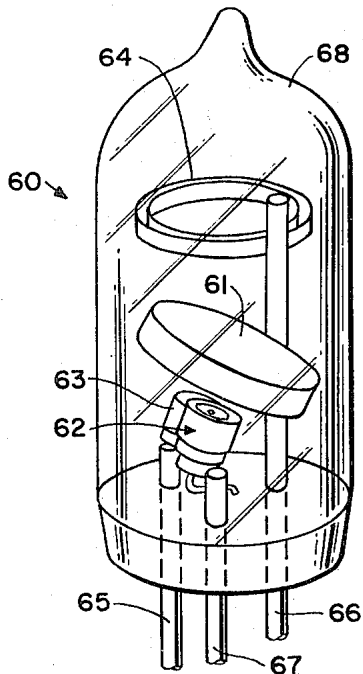

Fig. 6



Fig. 1 A

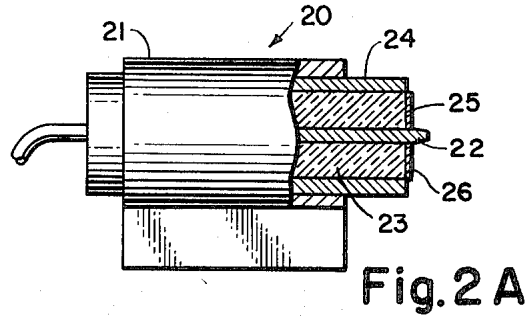

Fig. 2 A

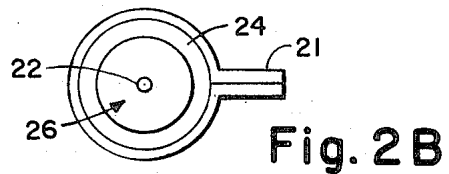

Fig. 2 B

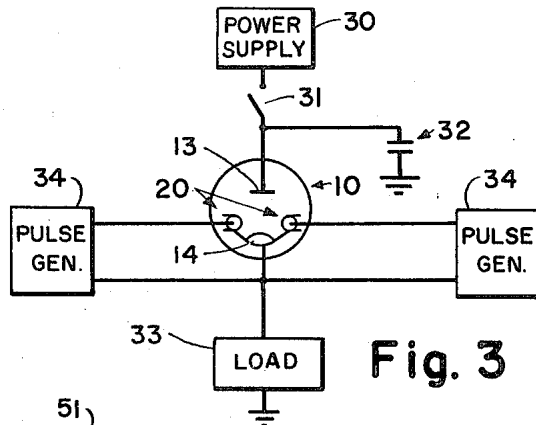

Fig. 3

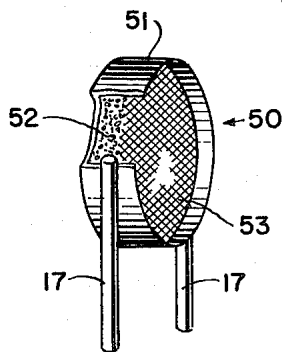

Fig. 5

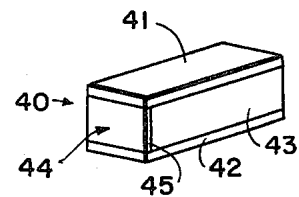

Fig. 4

INVENTOR.  
Gordon E. Boettcher

BY  
*Robert A. Goodenough*  
Attorney

## COLD CATHODE VACUUM DISCHARGE TUBE WITH CATHODE DISCHARGE FACE PARALLEL WITH ANODE

### BACKGROUND OF INVENTION

Triggered cold cathode discharge tubes are used in any application requiring fast response electric switching of large currents. Such tubes are normally connected in open circuit relationship between a source of electric current and a load. The tube is then pulsed by a suitable signal to effect an electric discharge within the tube, thus switching the tube to electrical conduction and passing a current pulse from the source to the load.

Some applications in which triggered discharge tubes have been used include radar systems, X-ray tube pulsing, high energy physics, power supplies and capacitor bank discharging. Increasingly in modern technology, a premium is placed on size and reliability of circuit components and the energy needed to operate the components. This is a particular problem in space systems since the available space and power capabilities may be extremely limited. Further, in view of their inaccessibility, such components must have stable operating characteristics over a long life span and must be simple and dependable.

Many prior triggered discharge tubes employed a gaseous atmosphere, often at high pressures, within the tube to enhance or effect the discharge. Such tubes generally are capable of fast switching response times with low energy trigger signals, however, these gaseous discharge tubes require long recovery times, relatively large size for a given hold-off voltage capability and relatively low hold-off voltage capabilities for a given electrode geometry. Further, such tubes may be triggered when the tube is subjected to its normal anode voltage and an external gamma radiation environment, since the gamma radiation ionizes the gas initiating a discharge. Some triggered gaseous discharge devices also include a keep-alive electrode to lower the response time and the trigger energy required to fire the device but consequently requires additional circuitry.

Prior triggered vacuum discharge tubes have provided lower recovery times and higher hold-off strength for a given electrode geometry than comparable gaseous tubes, however, such tubes have had relatively short life spans due to the accumulation of gaseous material within the tube after a number of operations. This accumulation of gas also subjects the tube to gamma radiation triggering. Further, such tubes have required unacceptably high triggering energies to initiate a discharge, sometimes over about 80,000 ergs. Also, some prior triggered vacuum discharge tubes have used a ceramic envelope which required ceramic to metal seals around the electrodes and leads which are difficult to attain or maintain and increase the cost and size of the tube.

### SUMMARY OF INVENTION

In view of the limitations of the prior art as noted above, it is an object of this invention to provide a triggered vacuum discharge tube requiring low trigger energies.

Further, it is an object of this invention to provide a triggered vacuum discharge tube having a faster response time, low recovery time and higher hold-off strength and the capability of maintaining the same over the life of the tube.

Further, it is an object of this invention to provide a triggered vacuum discharge tube which is small in size and inexpensive to manufacture.

Various other objects and advantages will appear from the following description of one embodiment of the invention, and the most novel features will be particularly pointed out hereinafter in connection with the appended claims.

The present invention comprises a cold cathode vacuum discharge tube having an anode and a cathode separated by a vacuum discharge gap, a spark source mounted generally parallel with and contiguous to said cathode and facing said anode, an evacuated envelope surrounding said anode, cathode and spark source, means for connecting said anode

and cathode to a high voltage source and for mounting said anode and cathode within said envelope and means for connecting said spark source to a trigger pulse source.

### DESCRIPTION OF DRAWINGS

The present invention is described in the accompanying drawings wherein:

FIG. 1 is a partially cutaway perspective view of a cold cathode vacuum discharge tube in accordance with this invention;

FIG. 1A is a cross-sectional view of the getter electrode;

FIG. 2A is an enlarged elevation view partially in cross-section of a trigger probe of this invention;

FIG. 2B is a right elevation view of the face of the trigger probe;

FIG. 3 is a schematic diagram of a circuit with vacuum discharge tube in accordance with this invention;

FIG. 4 is a perspective view of another embodiment of the trigger probe;

FIG. 5 is a partially cutaway view of an alternative anode design; and

FIG. 6 is a perspective view of another embodiment of this invention.

### DETAILED DESCRIPTION

In the embodiment of the invention shown perspective in FIG. 1, vacuum discharge tube 10 includes an evacuated envelope 11 having a sealed end portion 12 enclosing an anode 13 separated from a cathode 14 by a discharge gap 15 and a getter ring electrode 16. Anode 13, cathode 14 and getter ring electrode 16 are supported by leads or posts 17, 18 and 29 respectively, which are hermetically sealed to end portion 12 of envelope 11. The anode and cathode leads are shown in this embodiment as a pair of leads 17 and 18 which thus provide a greater current conducting capability for the tube. In addition to the insulation provided by the vacuum itself leads 17 and 18 are further insulated from each other by suitable insulators or stand-offs 19. Leads 17 are connected to a power source (not shown) such as a bank of capacitors while leads 18 are connected to a load (not shown).

Envelope 11 may be glass or any other gas impervious material which can be readily evacuated, closed and sealed to form the tube enclosure in a manner well known in the art. The envelope is preferably evacuated to at least a pressure of about  $10^{-8}$  mm mercury. Anode 13 may be any generally flat or plate shape but is shown for ease and simplicity of construction as being formed by wrapping a sheet of an electrically conductive metal around leads 18 and welding or attaching the anode thereto. For high amount and high energy discharges, the anode and cathode are preferably a refractory metal, such as niobium or tantalum or, where operating conditions permit such as for low current and/low energy discharges, a conductive material such as copper may be used. Anode 13 and Cathode 14 should be made of a suitable conductive material having the desired work function and operating characteristics for a discharge electrode. Stand-offs 19 can be insulators such as a ceramic bushing or a raised portion of the end portion 12 of envelope 11 itself. All elements of the tube are preferably heated in a vacuum before assembling the tube to remove all gases from the elements.

A channel or slot 27 in getter ring electrode 16 (shown in cross-section in FIG. 1A) is conventionally filled or partially filled with a gettering material power such as barium. Radio frequency current is applied to the getter ring after evacuating the tube through lead 29 in a manner well known in the art, thus heating and vaporizing the barium powder. The vaporized barium is then deposited as a film (not shown) on the inside surface at the top of envelope 11 forming the getter for tube 10.

Either one or a plurality of similar trigger probes 20, shown in greater detail in FIGS. 2A and B, are mounted contiguous with cathode 14 in openings in the cathode by clamping bands

21. In this embodiment two probes are shown to increase trigger isolation where it is desirable to have more than one trigger signal source since either probe can initiate a discharge between the anode and cathode. As shown in FIGS. 2A and B, trigger probe 20 comprises a central trigger pin 22 extending along the longitudinal axis of probe 20, a cylindrical ceramic member or bushing 23 concentrically surrounding trigger pin 22 and an aluminum ring or collar electrode 24 concentrically surrounding bushing 23. Trigger pin 22 extends slightly from the face of bushing 23 forming a generally planar spark gap with ring electrode 24 across the face of bushing 23. Clamping band 21 is wrapped around probe 20 in electrical contact with ring electrode 24 and then attached or welded to cathode 14 so that the spark gap of probe 20 faces anode 13 and discharge gap 15 generally parallel and adjacent to the face of cathode 14. Pins 22 are connected to leads 28 which are in turn connected to a pulse or signal generating means (not shown).

The exposed face 25 of bushing 23 has an electrically conductive coating 26 disposed thereon to reduce the effective spacing between trigger pin 22 and ring electrode 24 and to furnish a supply of gas and metal vapor to discharge gap 15. Coating 26 may be applied to bushing 23 by painting or doping face 25 with a colloidal solution of a conductive material such as niobium diselenide or carbon.

In an actual probe constructed in accordance with this invention, the trigger pin was a molybdenum wire having an outside diameter of about 0.009 inch, the ceramic bushing was about 0.060 inch long and had an inside diameter of about 0.01 inch and an outside diameter of about 0.04 inch and the ring electrode was an aluminum sheet about 0.01 inch thick. Probes have also been constructed in accordance with this invention having proportionately smaller dimensions about one-half of those described above. Trigger pin 22 can be a conductive refractory metal such as molybdenum, tantalum or titanium. Bushing 23 can be a porous ceramic material such as aluminum oxide or any other conventional ceramic. Ring electrode 24 can be a low vapor pressure conductive material such as aluminum which will erode during the main discharge. Colloidal solutions of carbon and water with a wetting agent may be employed having carbon particle sizes less than 1 micron, e.g. 20 millimicron and 70 millimicron, which become imbedded in the ceramic surface of bushing 23 when the coating is dried. After the tube 10 has been assembled and while it is being evacuated, current pulses are applied across the spark gap, about 70 to 120 amps peak, until the probe resistance is about 50 to 100 K ohms. The main discharge is also fired while the tube is being evacuated to outgas the other parts of the tube.

Vacuum discharge tube 10 is shown in the circuit diagram of FIG. 3 to illustrate the operation of the tube. In FIG. 3 anode 13 is connected to power supply 30 through switch 31 and storage capacitor 32, cathode 14 is connected to a load 33 and trigger probes 20 are connected to generally identical pulse or signal generators 34.

In operation, switch 31 is closed, thus charging capacitor 32 to the voltage supplied by voltage source 30. After capacitor 32 has been charged, switch 31 can be opened. Upon the application of a trigger pulse to either probe 20 by pulse generators 34, a field emission arc occurs across the doped ceramic surface of bushing 23 between trigger pin 22 and ring electrode 24. The arc heats the imbedded particles of coating 26 releasing gas and metal vapor into the discharge gap between anode 13 and cathode 14. This "puff" of gas and vapor initiates the main discharge between the anode and cathode thus producing the desired current pulse to load 33. During the main discharge, ring electrode 24 is eroded slightly by the discharge and a portion of the resulting metal particles settle on the surface of bushing 23. These particles then become part of coating 26 for subsequent triggered spark discharge across the probes 20, thus replenishing the coating. During and after the main discharge, any residual gases or vapors are gettered by the barium getter on the surface of envelope 11.

A discharge tube constructed in accordance with this invention having a pair of trigger probes with the above detailed dimensions, an anode-cathode spacing of about 0.2 inch in an envelope having about a 0.57 inch diameter and about 1.25 inches long, displayed the following capabilities:

Trigger signal	2000 ergs
Main discharge voltage	2,000-10,000 volts DC
Cathode current	12,000 amps (2.4 microsecond pulse)
Holdoff voltage	above 20,000 volts
Main discharge delay time	1.0 to 2.5 microseconds
Tube life	greater than 480 pulses
Maximum delay time variation	80 nanoseconds

15 Discharge tubes can be made in accordance with this invention by varying anode-cathode spacing, electrode material and trigger probe resistance to attain a wide variation of tube operating characteristics. Highly effective tubes trigger with a low energy 50-200 volt pulse (about 200-2,000 ergs) for anodes operating from 100-10,000 volts DC to provide current switching of from several amps to 13,000 amps. The holdoff voltage is dependent, among other things, upon the spacing between the trigger pin or cathode and the anode and the vacuum.

25 Probe 20 may be constructed in other than the coaxial configuration shown in FIGS. 2A and B, to provide similar operating characteristics. In FIG. 4, probe 40 comprises first and a second generally flat electrodes 41 and 42 attached or brazed to a ceramic member 43 which is disposed intermediate the electrodes. Electrodes 41 and 42 form a planar spark gap 44 across the face of member 43. The face of ceramic member 43 has an electrically conductive coating 45 disposed thereon similar to coating 26 on probe 20. The materials, mode of operation and relative dimensions of probe 40 are similar to probe 20. Probe 40 may be mounted in tube 10 contiguous with cathode 14 so that spark gap 44 is generally parallel with the cathode and facing anode 13 and the discharge gap in the same manner as probe 20.

40 In order to maintain a short main discharge delay time, the spark gap and ceramic member or bushing face is preferably close to the discharge gap without adversely affecting the holdoff voltage. In order to minimize the variation of the main discharge delay time over the life of the tube and to lower the voltage tube drop, the anode shown in FIG. 5 may be substituted for the plate type anode of FIG. 1.

45 In FIG. 5, anode 50 comprises a metal cup 51 and a mixture 52 of potassium chloride (KCl) and aluminum (Al) filings covered by a metal mesh or screen 53. Anode 50 is mounted and supported in a discharge tube in the same manner as anode 13 in FIG. 1 by electrodes 17. Cup 51 and mesh 53 can be any metal electrode material such as nickel or tantalum. Mesh 53 serves to hold the KCl-Al mixture 52 in place and to carry the discharge current from the mixture to cup 51. Mixture 52 is preferably about 60-65 percent by weight KCl. Anode 50 can be substituted for the plate type anode shown in FIG. 1 in any application requiring the operating characteristics peculiar to anode 50.

50 FIG. 6 illustrates another embodiment of this invention which uses an anode constructed in accordance with the anode illustrated in FIG. 5 and which may be employed for lower discharge voltage and current applications. In FIG. 6, vacuum discharge tube 60 comprises a cup anode 61, trigger probe 62, trigger probe mounting band and cathode 63 and getter ring 64. Trigger probe 62 has the same trigger pin, ceramic bushing and ring electrode as that illustrated in FIGS. 2A and B. The mounting band shown in FIGS. 2A and B is used in this embodiment as cathode 63. Cathode 63 is welded to and supported by lead 65. Anode 61 is welded to and supported by the getter ring lead 66 which serves as an anode lead after the gettering material has been evaporated. The trigger pin of probe 62 is connected to lead 67. The electrodes are enclosed within and the leads are hermetically sealed to evacuated envelope 68 in a similar manner as FIG. 1.

A discharge tube constructed in accordance with FIG. 6 may have a length of 0.5 inch and outside diameter of 0.28 inch for switching 100-2,000 volts in 0.85 microseconds at several amps to 2,000 amps using a 200 erg trigger signal (200 volts, 0.7 amp pulse). The tube had a holdoff voltage of about 4,000 volts, exhibited a 0.1 to 0.3 microsecond discharge delay time and had a tube life in excess of 2,000 pulses.

Vacuum discharge tubes can be made in accordance with this invention which require relatively low energy trigger signals for a given discharge voltage and current, which are capable of switching a wide range of discharge pulses, which have long life, which display all the advantage of vacuum discharge devices such as high holdoff voltages and radiation hardness and which are simple and inexpensive to manufacture and small in size. A tube incorporating the features of this invention and having a normal discharge voltage impressed between the anode and cathode has been subjected to gamma radiation in excess of about 10<sup>13</sup> rads per second at a dose in excess of about 10<sup>5</sup> rads without initiating a discharge within the tube.

It will be understood that various changes in the details, material and arrangements of the parts, which have been herein described and illustrated in order to explain the nature of the invention, may be made by those skilled in the art within the principles and scope of the invention as expressed in the appended claims.

What is claimed is:

- 1. A cold cathode vacuum discharge tube, comprising
  - a. an anode,
  - b. a cathode having a discharge face parallel to said anode and separated from said anode by a vacuum discharge gap,
  - c. a spark source including a ceramic member, a first electrode, and a second discharge-erodible electrode, said ceramic member disposed intermediate said electrodes, the ceramic member and second electrode having end faces disposed toward said discharge gap substantially coplanar with each other and with adjacent portions of

said cathode discharge face, said ceramic end face carrying a conductive coating formed by applying a colloidal suspension of conductive particles on said surface and drying said ceramic end face leaving said particles at least partially imbedded therein,

- d. means for connecting said spark source second electrode to said cathode,
- e. an evacuated envelope surrounding said, anode, cathode and spark source,
- f. a getter within said envelope,
- g. means for connecting said anode and said cathode to a source of high voltage and for supporting said anode and cathode within said envelope, and
- h. means for connecting said spark source first electrode to a trigger pulse source.

2. The cold cathode vacuum discharge tube of claim 1 wherein said conductive particles are carbon.

3. The cold cathode vacuum discharge tube of claim 2 wherein said carbon is in particles ranging from about 20-70 millimicrons in size.

4. The cold cathode vacuum discharge tube of claim 1 in which said first electrode is a trigger pin and said second electrode is a hollow cylindrical electrode disposed generally around said trigger pin.

5. The cold cathode vacuum discharge tube of claim 4 wherein said second electrode is aluminum.

6. The cold cathode vacuum discharge tube of claim 1 wherein said getter is disposed within a generally annular electrode of U-shaped cross section adjacent said discharge gap with opening of the U-shaped electrode facing toward said envelope, and means for connecting said U-shaped electrode to a power source and for mounting said electrode in said envelope.

7. The cold cathode vacuum discharge tube of claim 1 wherein said anode comprises a metal cup, a mixture of KCl and Al filings disposed within said cup and a metal screen means attached to said cup for holding said mixture in place and for conducting currents from said mixture to said cup.

\* \* \* \* \*

40

45

50

55

60

65

70

75